



Aluminium Tripod Crane

**Item No. 1621000**



**Technical Data**

load capacity ..... 1,000 kg  
weight ..... 54 kg

**Description**

- The ringbolt rotates through 360° under load.
- Greater adjusting range due to telescopic legs.
- Collapsible.  
Total length approx. 2,000 mm.  
Diameter approx. 450 mm (e.g. for transportation).
- Feet are fitted with non-slip rubber-metal linings.
- Stability guaranteed.
- Is designed for lifting loads especially in places that are hard to reach with conventional devices.

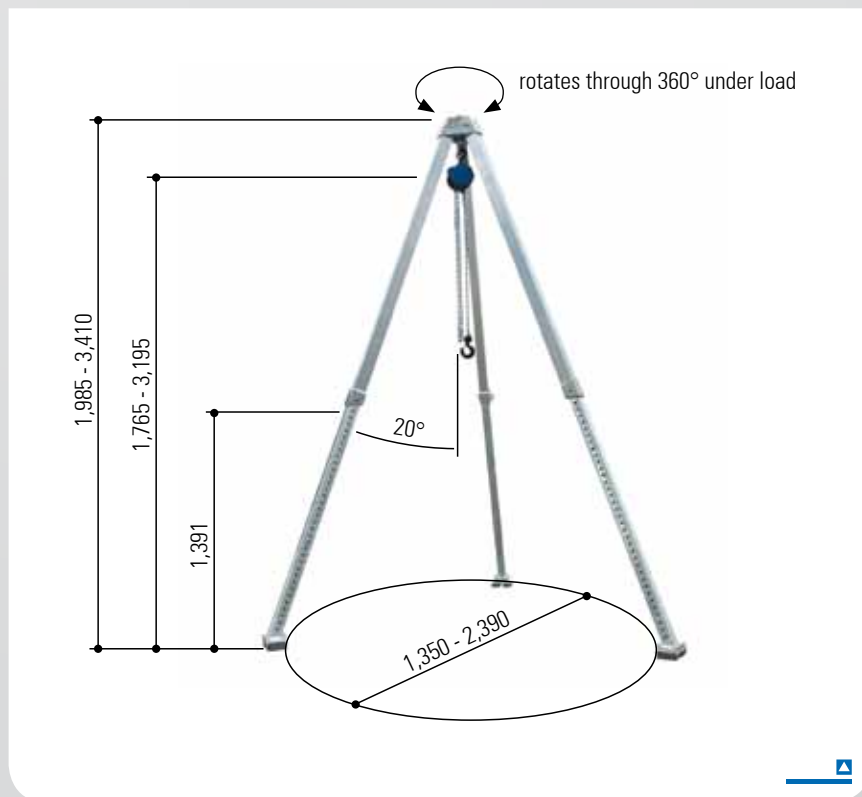

**Accessories**

- ▣ Chain Hoist ..... page 81